

PROGRAM
ASCAR I T-5

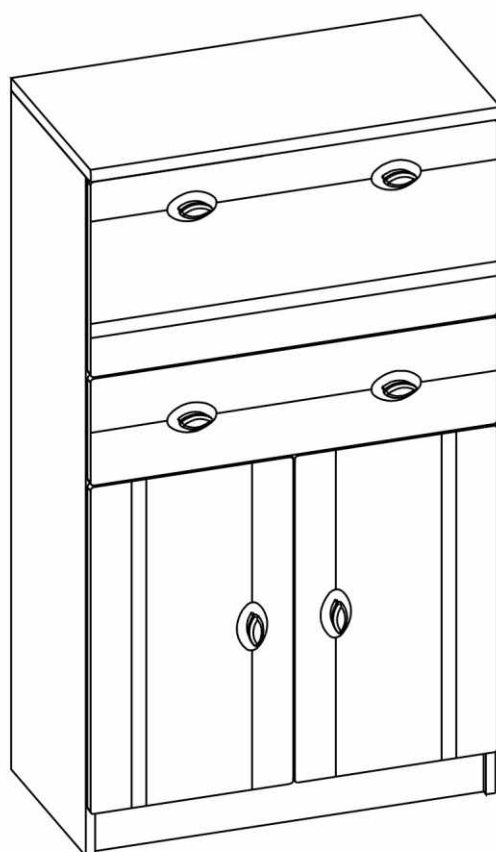

→ 700 ↑ 1230 ↘ 375

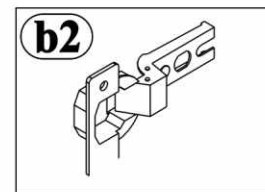
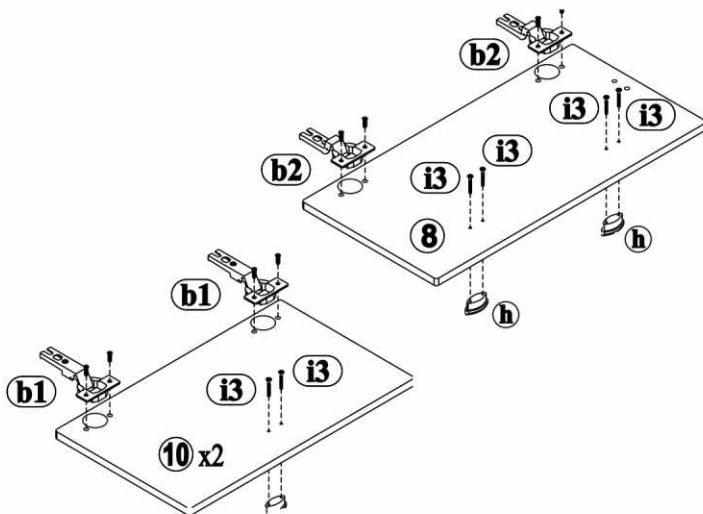
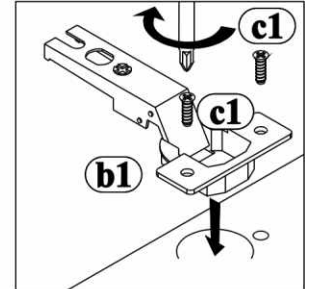
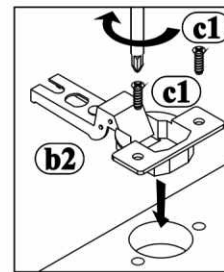
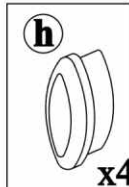
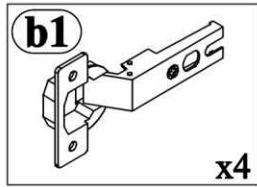
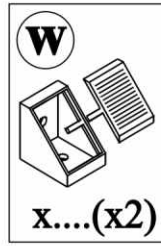
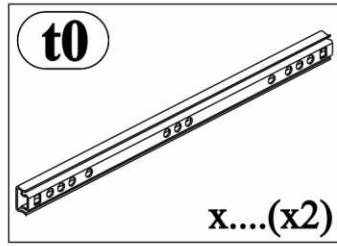
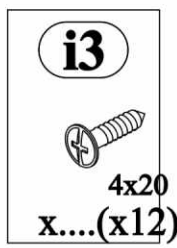
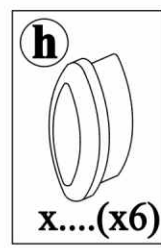
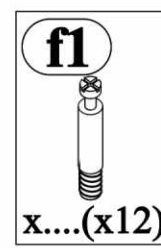
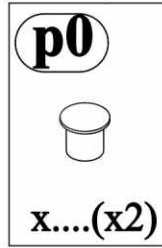
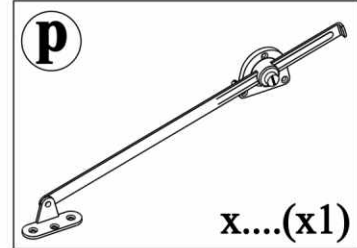
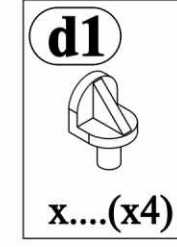
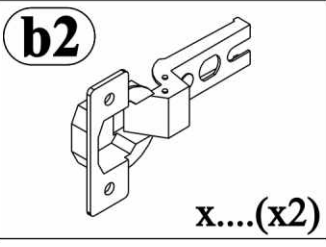
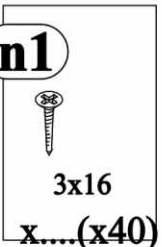
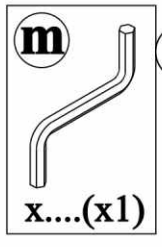
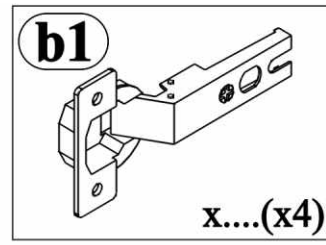
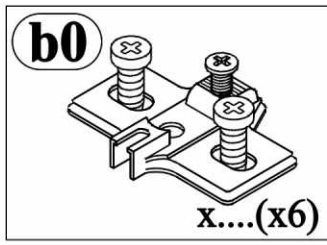
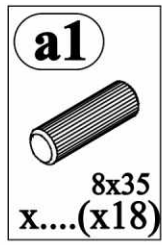
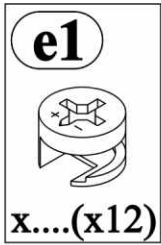
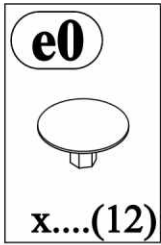

2

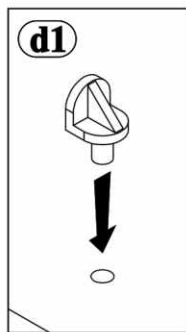
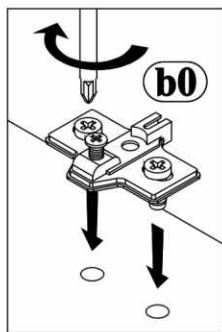
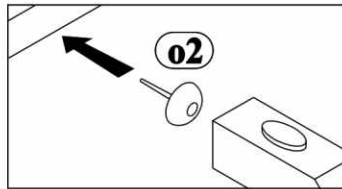
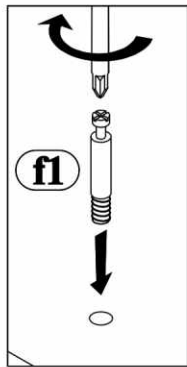
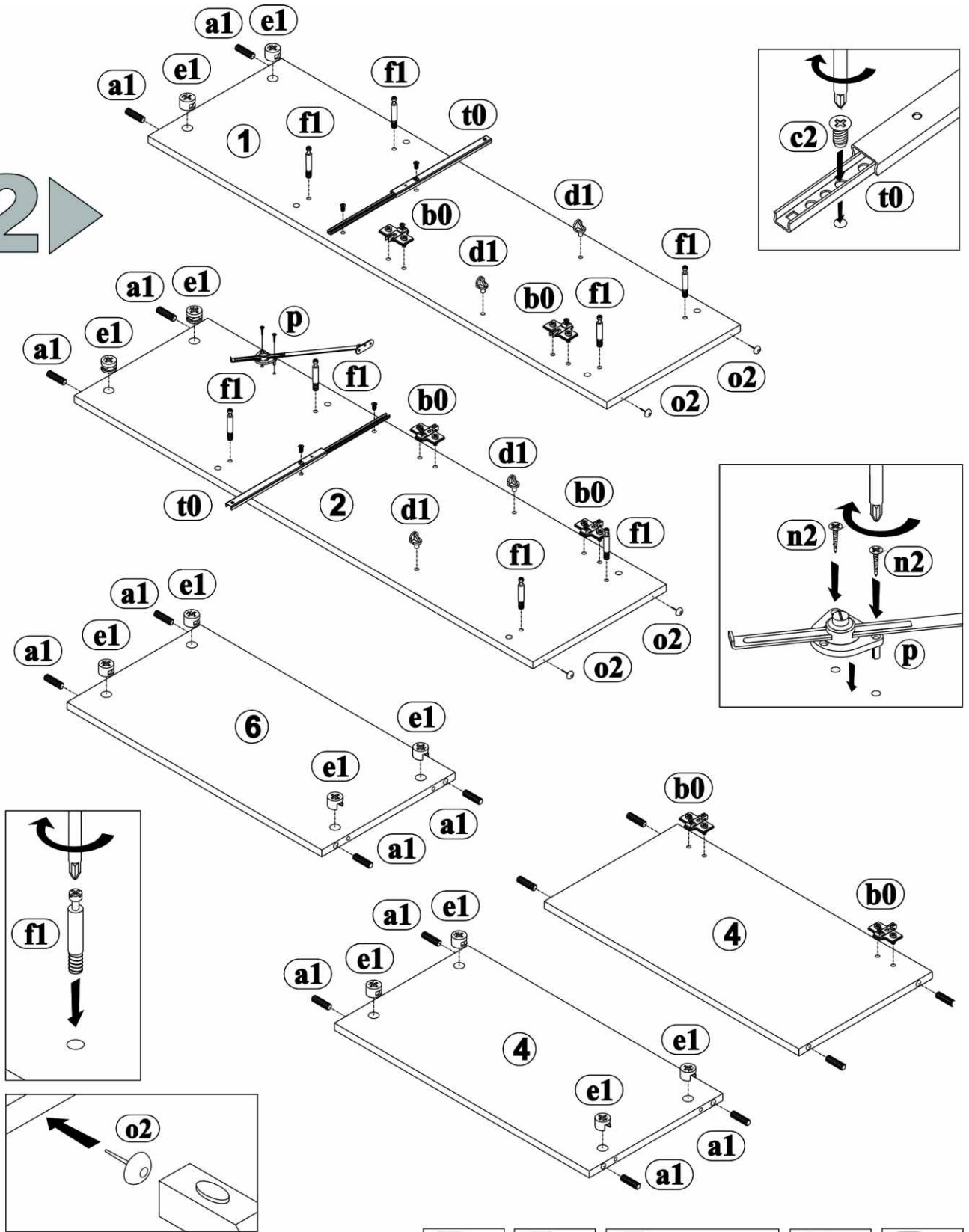

<p>a1</p> <p>8x35 x12</p>	<p>c2</p> <p>Euro 5x13 x4</p>	<p>b0</p> <p>x6</p>	<p>d1</p> <p>x4</p>	<p>e1</p> <p>x12</p>
<p>f1</p> <p>x8</p>	<p>n2</p> <p>3,5x16 x3</p>	<p>o2</p> <p>x4</p>	<p>p</p> <p>x1</p>	<p>t0</p> <p>x2</p>

3

3 ▶

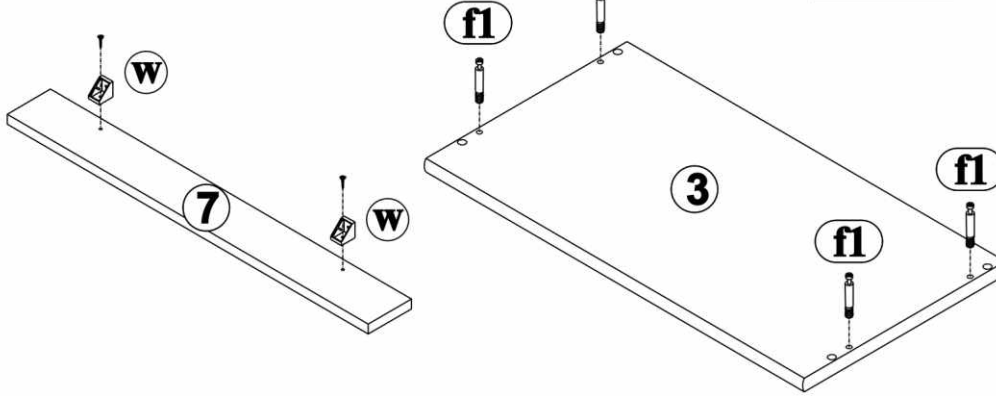
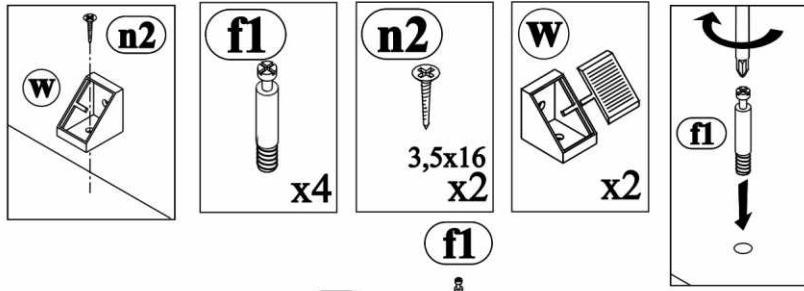

4 ▶

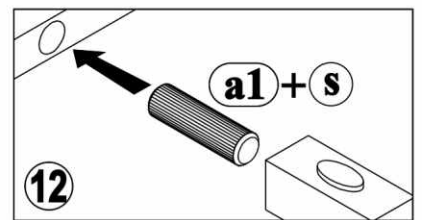
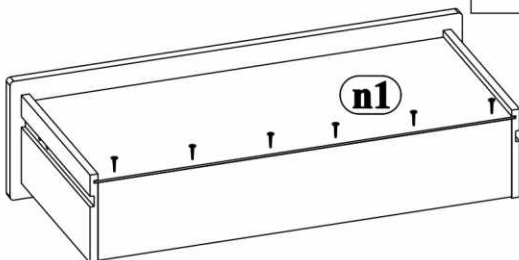
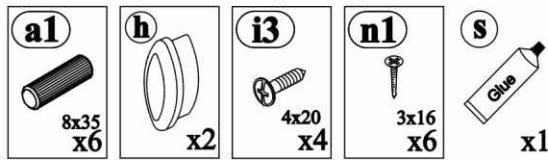
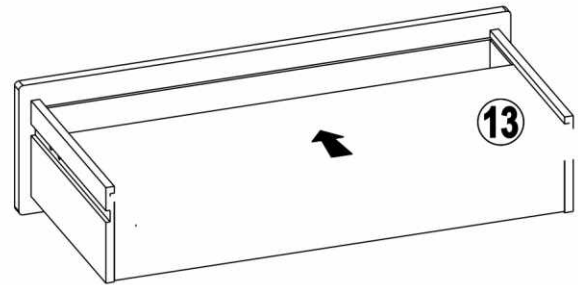
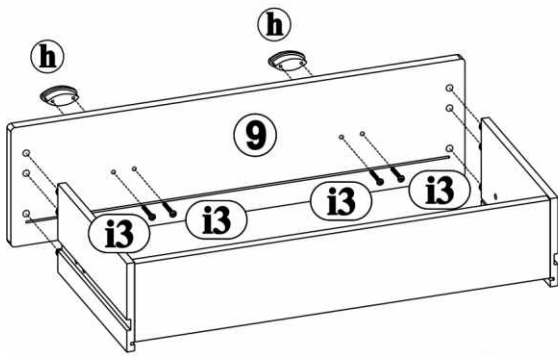
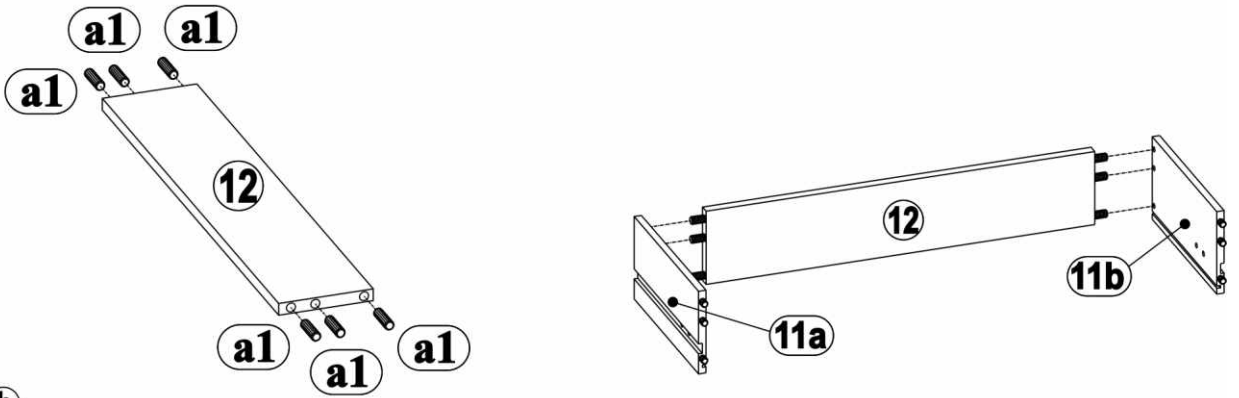

4

5

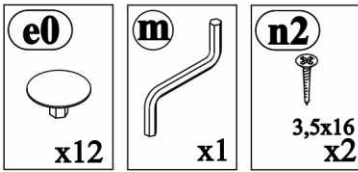
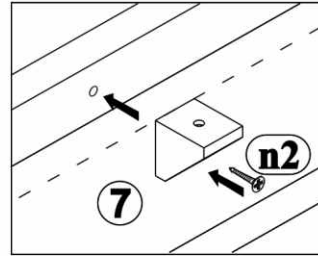
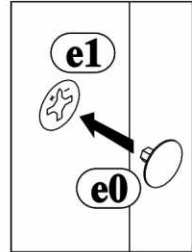
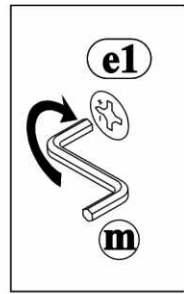
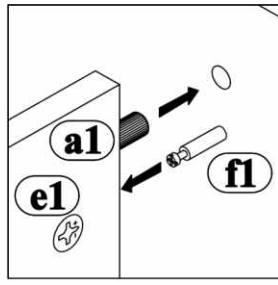
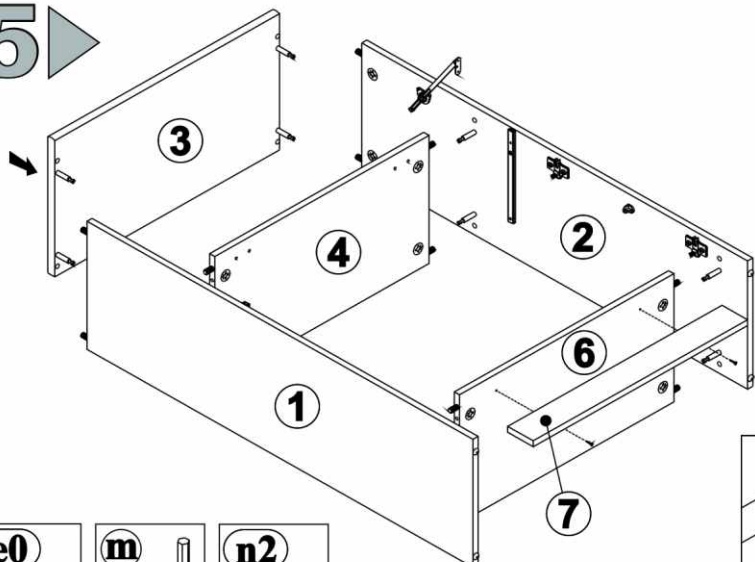

6

