

A	B	C	D	
1	S82-131	1926	540	1/4
2	S82-132	1926	540	1/4
3	S82-133	175	536	2/4
4	S82-134	175	536	2/4
5	S82-207	1011	540	2/4
6	S82-311	978	536	2/4
7	S82-405	978	78	2/4
8	S82-507	500	140	2/4
9	S82-508	500	140	2/4
10	S82-515	805	140	2/4
11	S82-551	1012	80	3/4
12	S82-564	1926	80	3/4
13	S82-565	1926	80	3/4
14	S82-909	815	498	2/4
15	S82-9907	1865	999	1/4
16	dr-971	971	30	2/4

4x  φ7x50 mm <b>e1</b>	8x  φ6x13 mm <b>e3</b>	40x  φ8x30 mm <b>f1</b>	4x  φ6.5x40 mm <b>f25</b>	4x  <b>k1</b>	70x  <b>l1</b>	2x  <b>n1</b>	2x  φ3.5x13 mm <b>p1</b>	2x  φ3.5x16 mm <b>p25</b>
4x  φ3x12 mm <b>p54</b>	42x  φ1.5x12mm #16 <b>r1</b>	2x  <b>r10</b>	4x  φ1.2x10.5mm #12 <b>r15</b>	42x  <b>r16</b>	16x  ø16 <b>s2</b>	1x  483 mm <b>t17</b>	1x  500 mm <b>w26\CL</b>	1x  500 mm <b>w26\CR</b>
1x  500 mm <b>w26\DL</b>	1x  500 mm <b>w26\DR</b>	1x  <b>z1</b>	1x  <b>n26\l</b>	1x  φ3.5x16 mm <b>p38</b>				

# 1

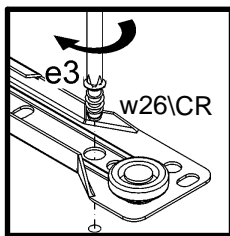
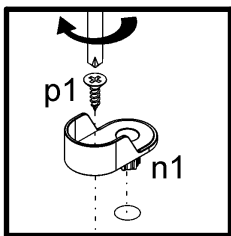
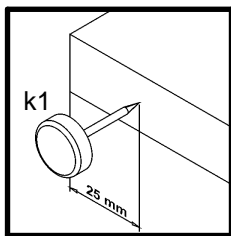
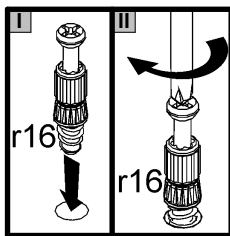
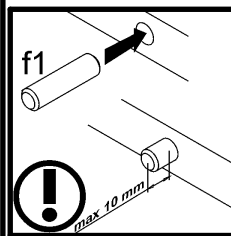
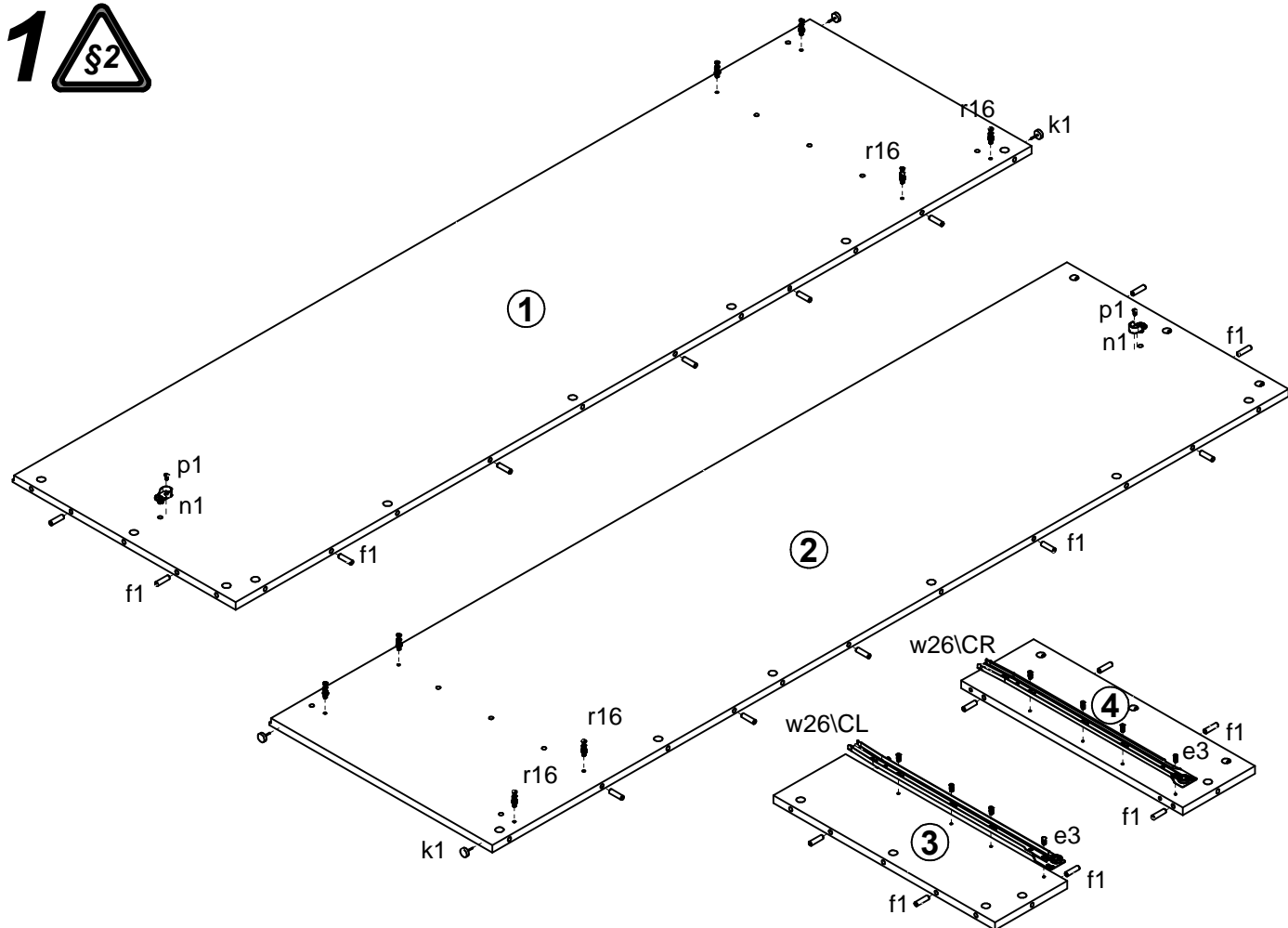

# 2

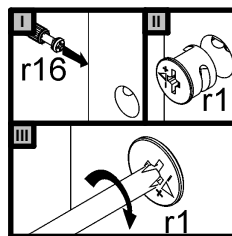
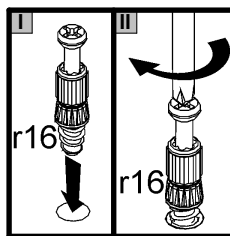
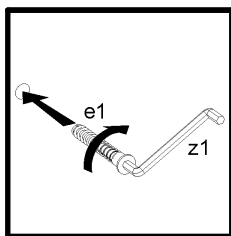
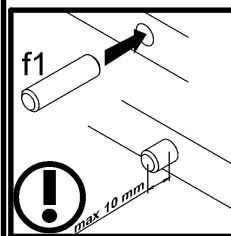
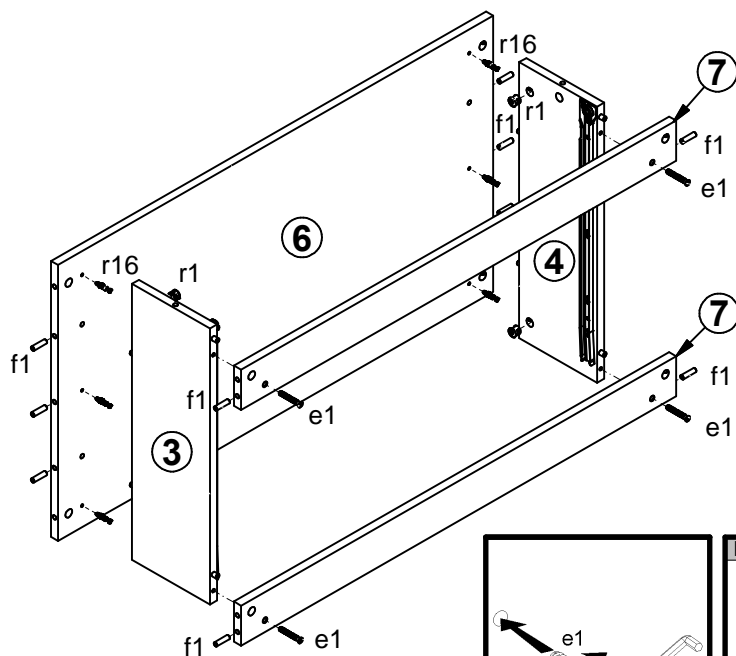

# 3

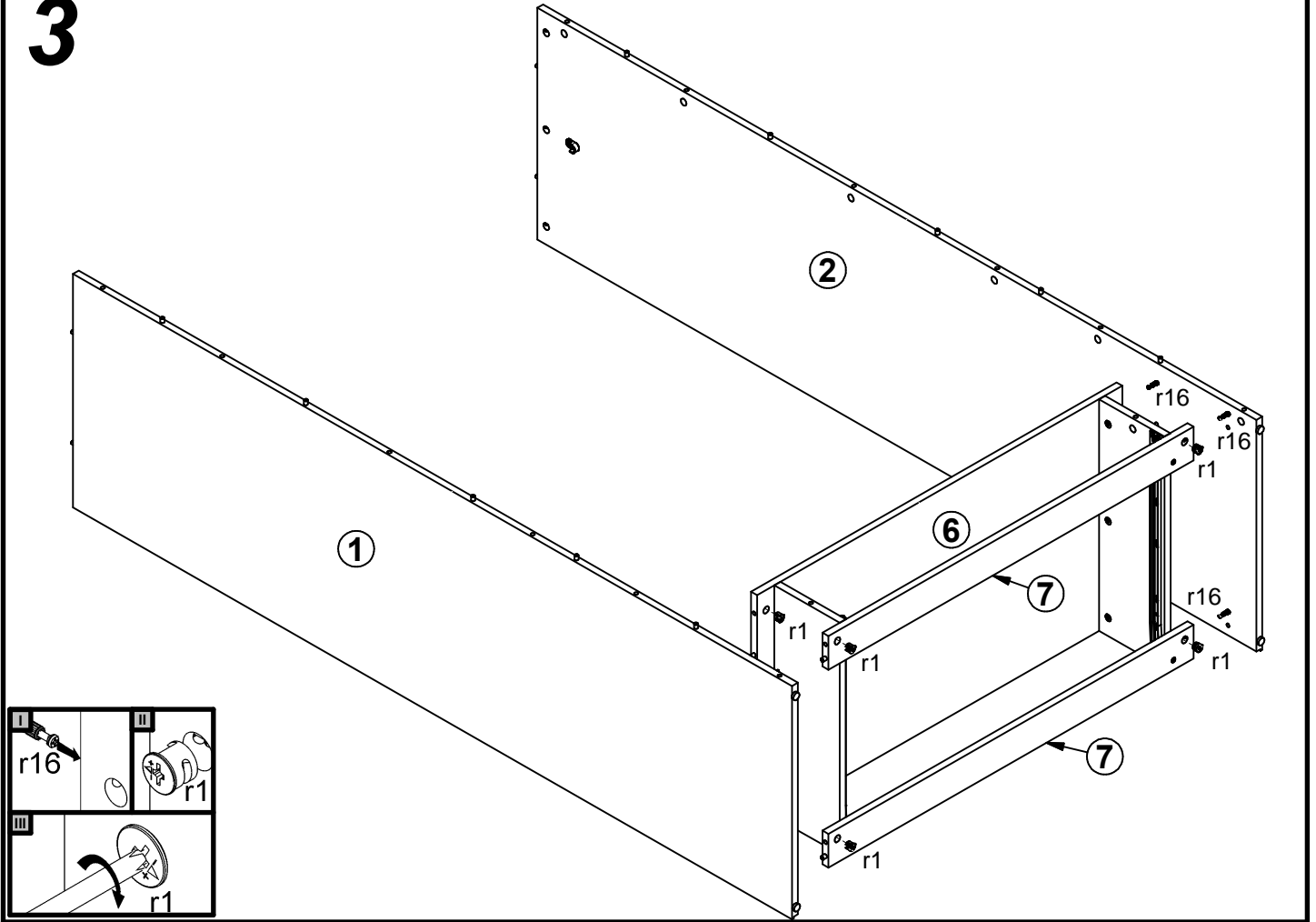

# 4

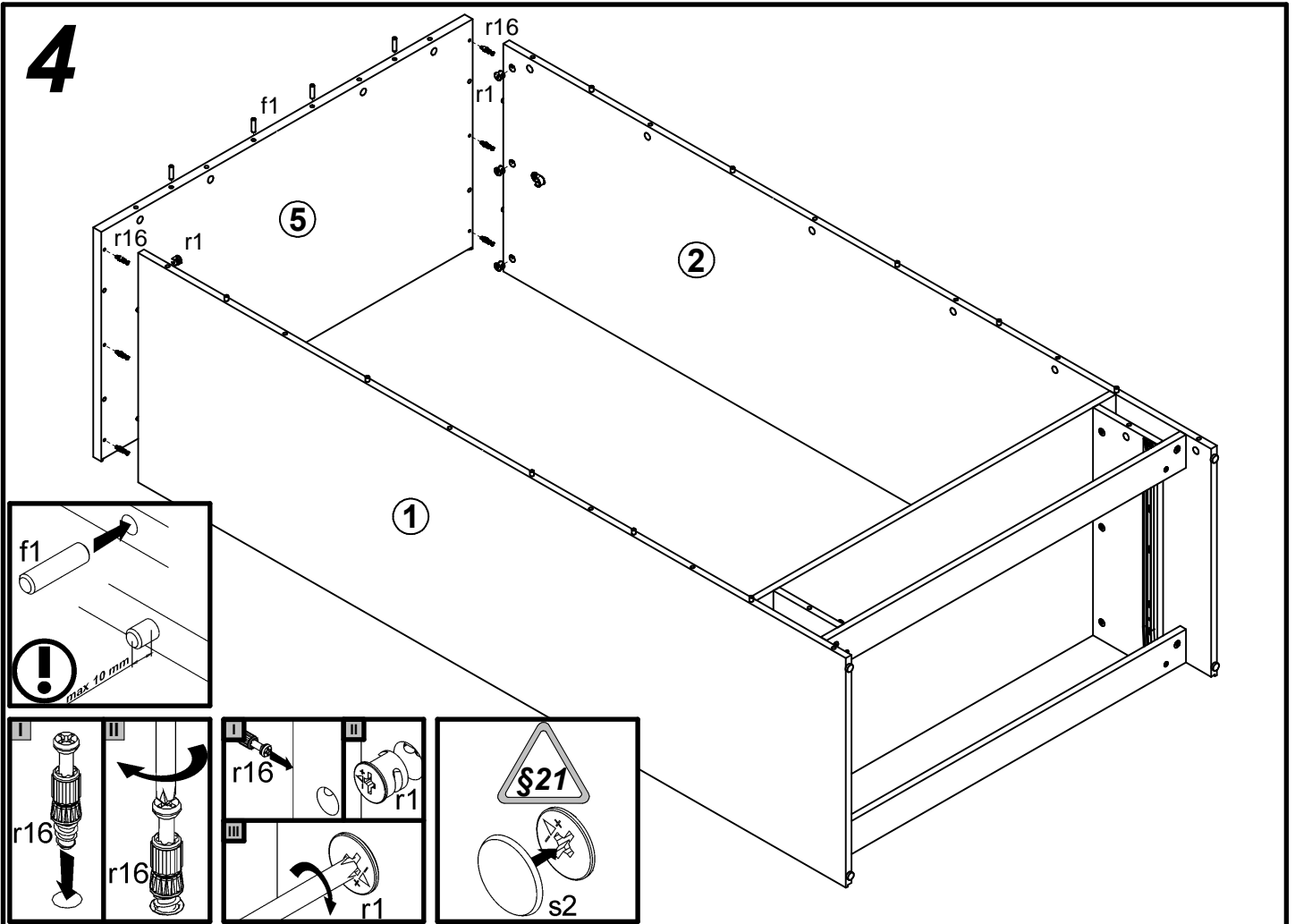

# 5

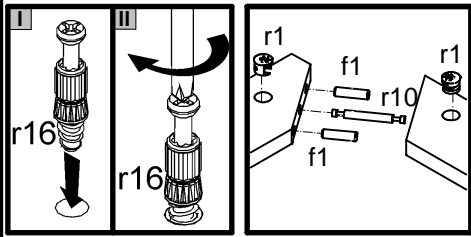
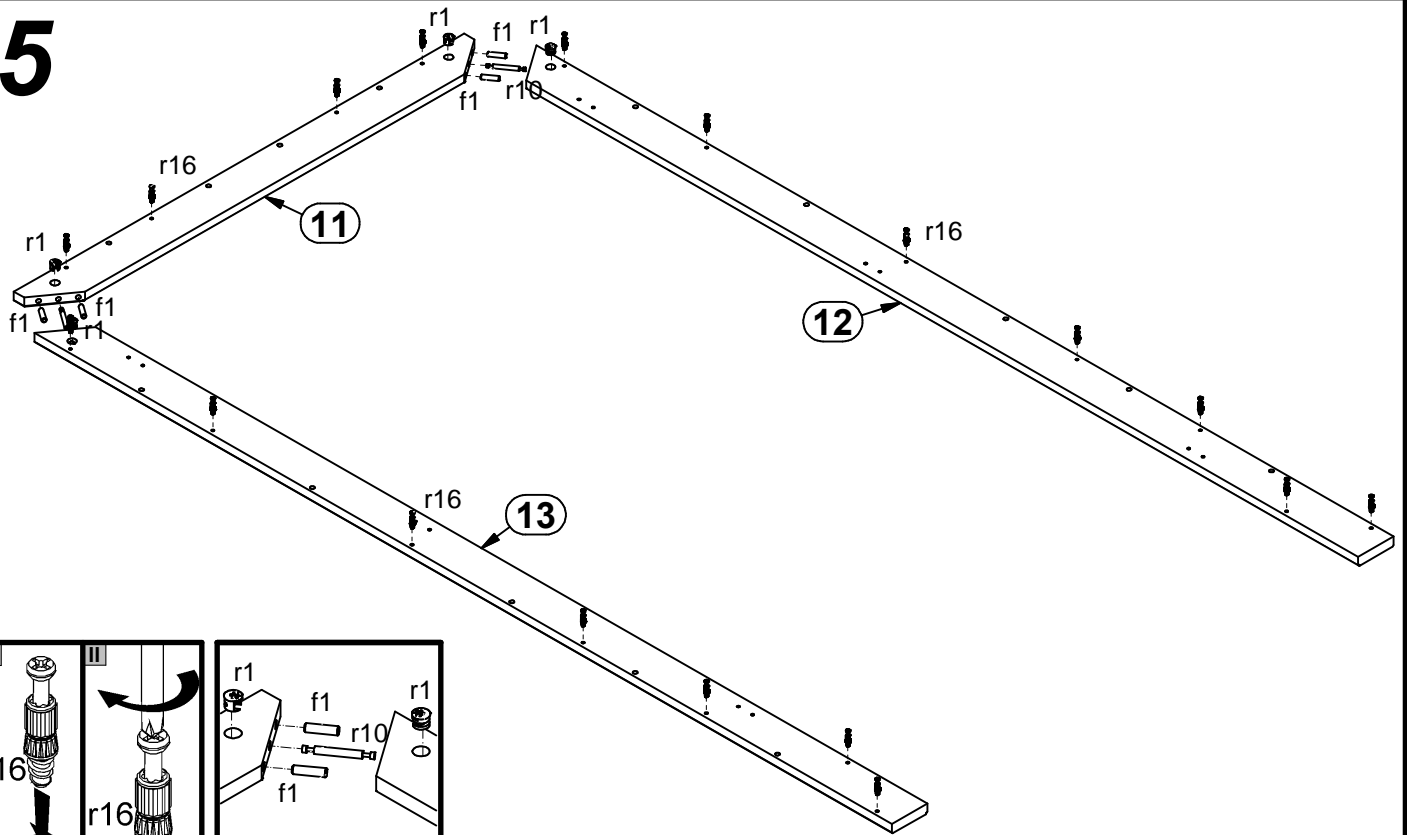

# 6

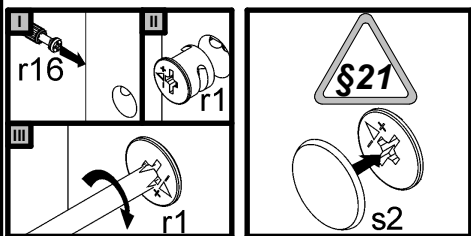
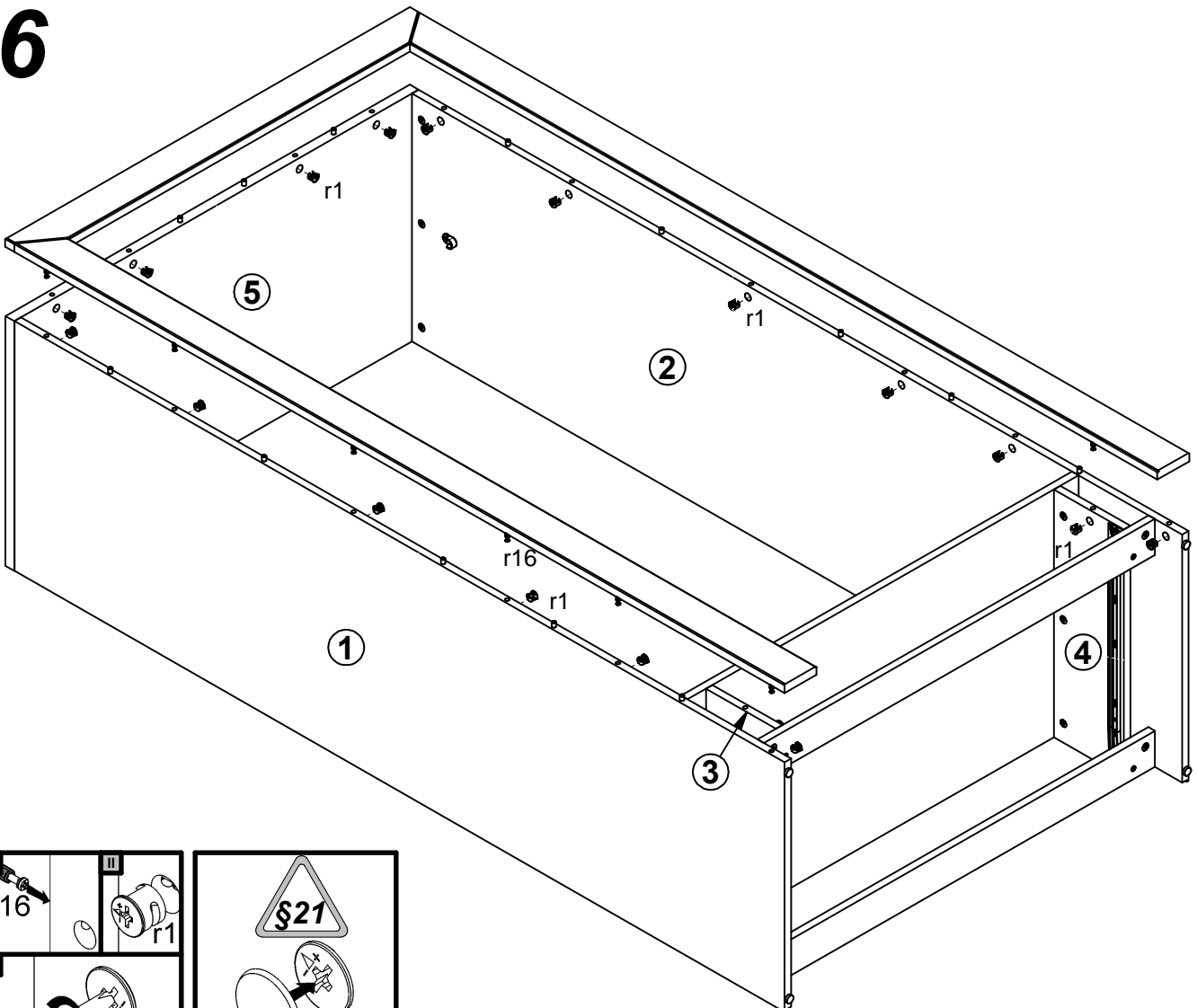

# 7

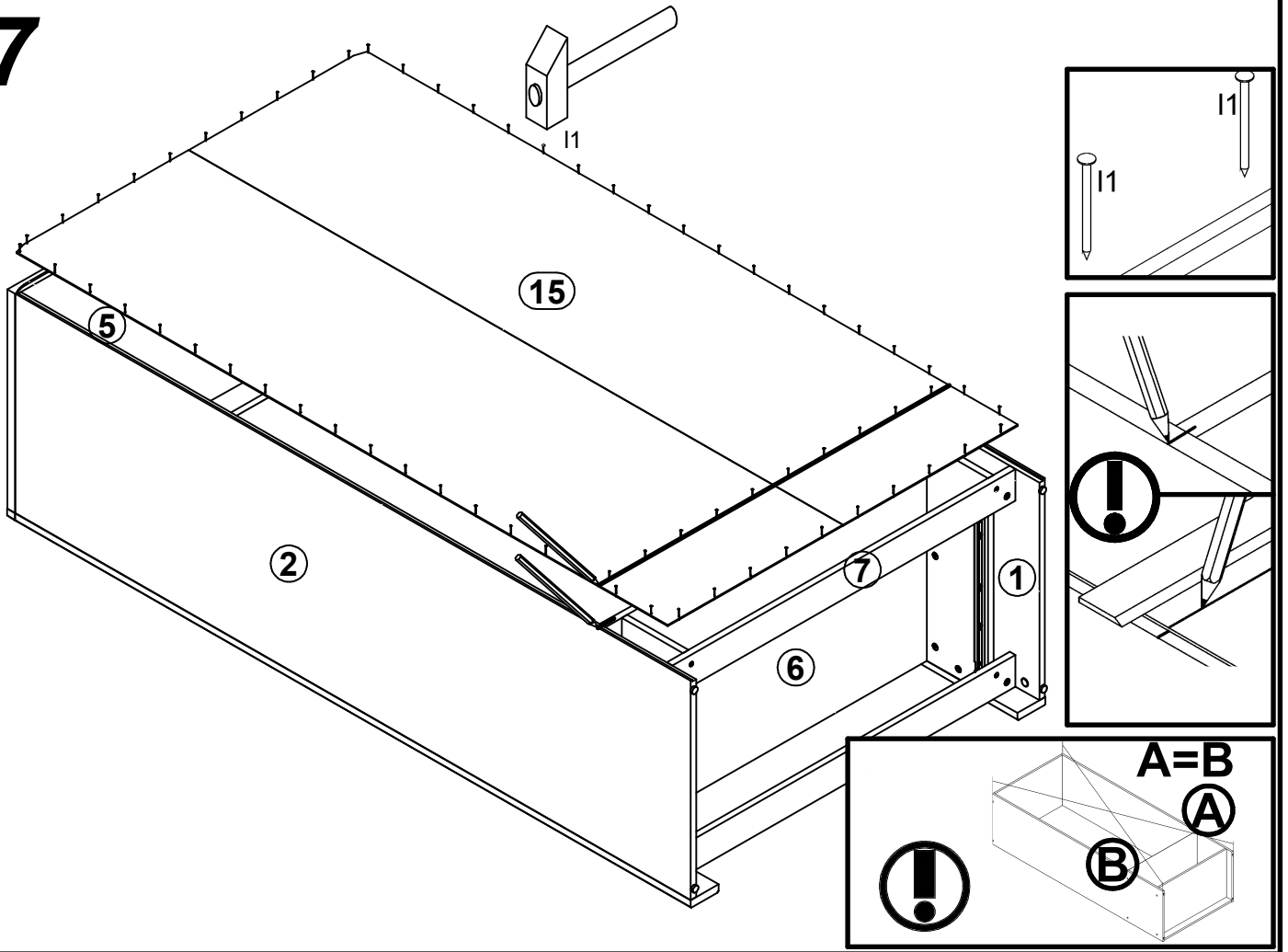

# 8

